

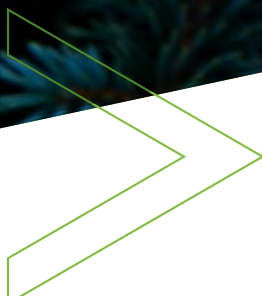

**KRATON™**

SUSTAINABLE SOLUTIONS.  
ENDLESS INNOVATION.™



BIO-BASED  
**TACKIFIERS FOR ADHESIVES**



## Table of Contents

- 3** Biobased Product Portfolio
- 4** Tackifiers for Adhesives
- 5** SYLVATAC™ and SYLVALITE™ Rosin Ester Tackifiers
- 6** UNI-TAC™ Modified Rosin Tackifier
- 6** AQUATAC™ Dispersion Tackifiers
- 7** SYLVARES™ AMS Tackifiers
- 7** SYLVARES™ AMS Phenolic Tackifiers
- 8** SYLVARES™ Styrenated Terpene Tackifier
- 8** SYLVARES™ Polyterpene Tackifiers
- 9** SYLVARES™ Terpene Phenolic Tackifiers
- 10** Global Integrated Team Approach
- 11** Innovative Solutions
- 13** Glossary
- 14** About Kraton Corporation

# Biobased Product Portfolio

Kraton's biobased products are derived from biomass. This is independently verified by the Biobased Certification Scheme, which specifies the amount of biomass in a product based on the European standard EN 16785-1. The European standard provides a method to determine the biobased content of solid, liquid and gaseous products using radiocarbon analysis and elemental analyses. Through this certification body, we are able to transparently and credibly communicate about our materials to customers and help them improve their products' sustainability performance. For more information, visit [www.biobasedcontent.eu](http://www.biobasedcontent.eu).

Biorenewable raw material

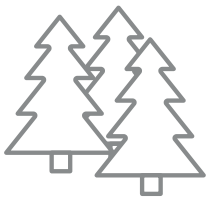

Using the co-product of pulp production



Refining and producing chemicals



Providing value-added pine chemicals to the adhesives industry

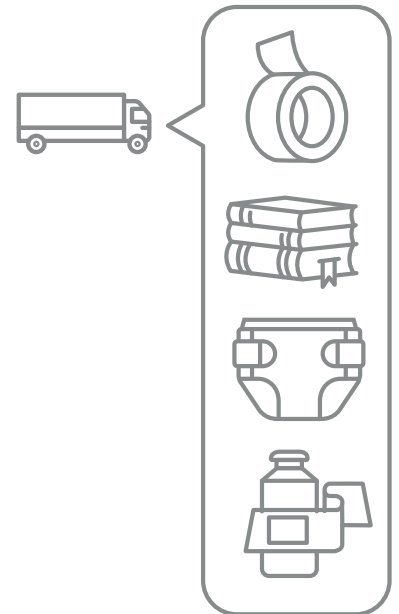

Kraton is the frontrunner in biorefining crude tall oil (CTO) and crude sulfate turpentine (CST), co-products of the Kraft wood pulping process. This process originates with pine forests harvested by pulp and paper manufacturers. Many of our primary suppliers have been certified to recognized accreditation standards that address responsible forest management. We emphasize maximization of the value of our raw materials while minimizing waste and environmental impact.

# Tackifiers for Adhesives

By working with a large and varied molecular asset base, Kraton's science and technology teams can select or create products that achieve desired performance results.

## POLYMER COMPATIBILITY

Compatibility between a tackifier and an adhesive polymer is a crucial factor in enhancing viscoelastic properties. In contrast, a certain amount of incompatibility can also provide desired properties. The Hildebrand solubility parameter gives an estimate of the degree of interaction between tackifier and polymer. Materials with similar values are likely to be miscible and have favorable viscoelastic properties.



# Hildebrand Solubility Parameter

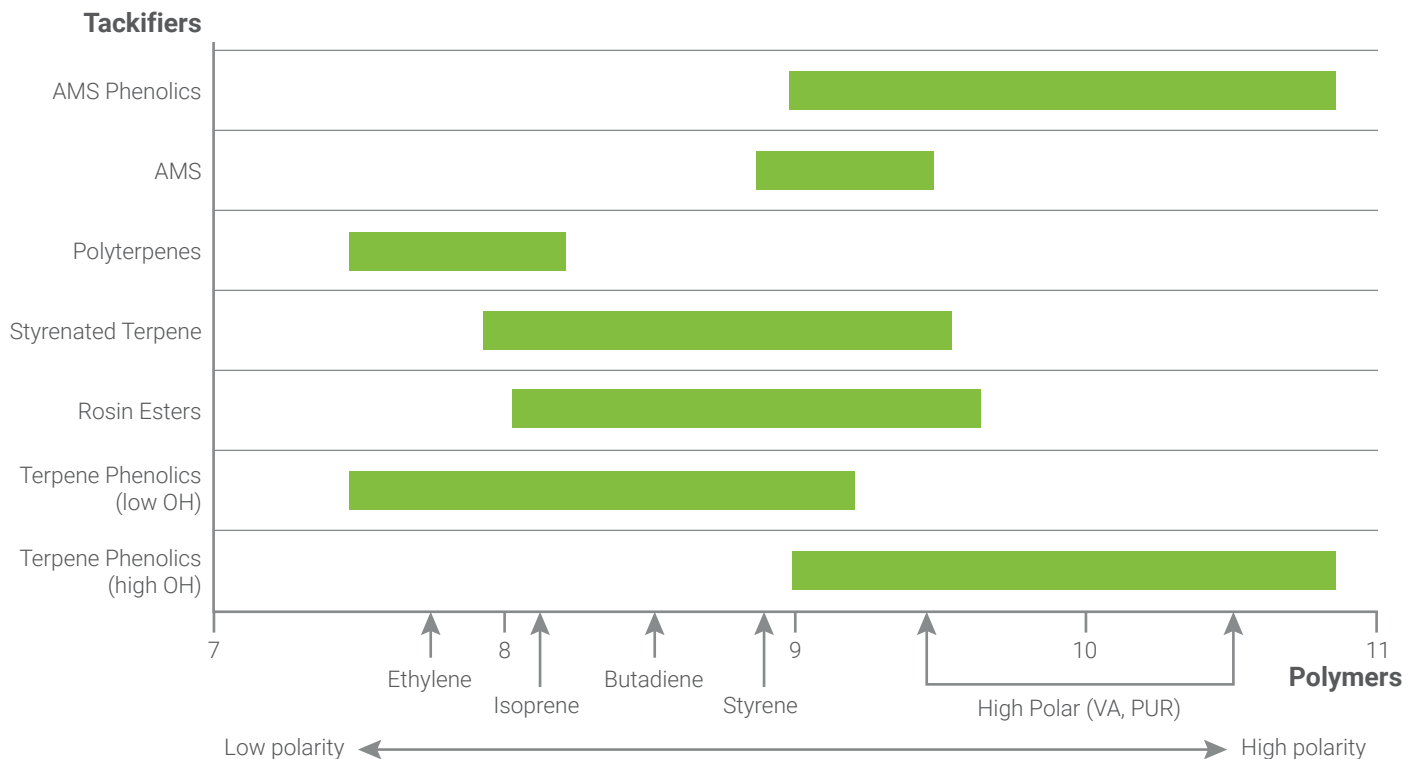

# SYLVATAC™ and SYLVALITE™ Rosin Ester Tackifiers

Rosin esters are compatible with a broad range of polymers, including high and low vinyl acetate EVA, acrylics, SBR, SIS and SBS. This characteristic enables formulation flexibility in various hot-melt, water-based and solventbased adhesive applications. Solid rosin esters can be formulated into SBC- or EVA-based adhesives for packaging, PSA and woodworking applications. In addition to these end uses, liquid rosin esters can also be used in water-based acrylic for construction adhesives.

At Kraton, we continuously upgrade our product line and introduced a new rosin ester: SYLVALITE 9000. This biobased tackifier combines differentiated adhesion with light color and advanced stability for the most stringent hot-melt adhesive requirements.

Test	SP	AN	Color		Tg	Manufacturing Region*
Method	AQCM 003	AQCM 001	AQCM 002		AQCM 218	
Unit	°C	mgKOH/g	Gardner (neat)	Gardner (1:1 toluene)	°C	
SYLVATAC™ RE 5S	liquid	16	-	7	-28	EU
SYLVALITE™ 2010	liquid	10	3	-	-30	US
SYLVATAC™ RE 12	liquid	12	-	2	-24	EU
SYLVATAC™ RE 25	29	22	2	-	-13	US
SYLVALITE™ 2038 37	13	3	-	-	-6	US
SYLVALITE™ RE 80HP	78	6	3	-	30	US
SYLVATAC™ RE 85 (US)	82	8	5	-	30	US
SYLVATAC™ RE 85 (EU)	83	4	-	2	33	EU
SYLVALITE™ RE 85GB	84	11	3	-	35	US
SYLVALITE™ RE 88F	88	5	-	1	41	EU
SYLVATAC™ RE 95	95	10	-	5	47	EU
SYLVATAC™ RE 98	95	16	5	-	46	US
SYLVATAC™ 2098	97	8	-	4	46	EU

\* Please contact your Sales Manager for product availability in your region.

The values presented in this brochure are average values for typical resin samples and should not be construed as product specifications. Kraton test methods are available upon request.

Test	SP	AN	Color		Tg	Manufacturing Region*
Method	AQCM 003	AQCM 001	AQCM 002		AQCM 218	
Unit	°C	mgKOH/g	Gardner (neat)	Gardner (1:1 toluene)	°C	
SYLVALITE™ 9000	103	6	-	1	54	EU
SYLVALITE™ ENDURA 99	98	9	4	-	49	US
SYLVALITE™ RE 100S	98	5	-	2	48	EU
SYLVALITE™ RE 100L	98	10	4	-	48	US
SYLVALITE™ RE 100F	100	5	-	2	52	EU
SYLVATAC™ RE 103S	102	7	-	3	52	EU
SYLVALITE™ RE 105XL	105	5	-	1	57	EU
SYLVALITE™ RE 105L	104	9	4	-	51	US
SYLVALITE™ RE 110L	107	11	4	-	57	US
SYLVALITE™ 2115	115	4	-	2	65	EU

\* Please contact your Sales Manager for product availability in your region.

## UNI-TAC™ Modified Rosin Tackifier

UNI-TAC™ 70 tackifier imparts outstanding adhesion to difficult-to-bond substrates due to the high acid number, non-crystallinity and low molecular weight of this highly polar solid rosin.

Test	SP	AN	Color	Tg	Manufacturing Region*
Method	AQCM 003	AQCM 001	AQCM 002	AQCM 218	
Unit	°C	mgKOH/g	Gardner (neat)	°C	
<b>UNI-TAC™ 70</b>	80	155	11	33	US

\* Please contact your Sales Manager for product availability in your region.

The values presented in this brochure are average values for typical resin samples and should not be construed as product specifications. Kraton test methods are available upon request.



## AQUATAC™ Dispersion Tackifiers

AQUATAC™ waterborne tackifiers have high solid content, which contributes to improving overall operational efficiency for adhesive manufacturers. These dispersed tackifiers are compatible with a broad range of water-based polymers including natural rubber, C-SBR, SBR, polychloroprene and acrylic latices. Our AQUATAC dispersion resins can be formulated to achieve optimum performance properties for both pressure-sensitive and non-pressure-sensitive adhesives.

Test	SP (base resin)	Solid Content	Viscosity	pH	Manufacturing Region*
Method	AQCM 003	AQCM 029	"AQCM 004 (Brookfield 25 °C)"	"AQCM 136 (EU) AQCM 035 (US)"	
Unit	°C	%	mPa.s / cps		
<b>AQUATAC™ XR-4343</b>	85	60	600	8.5	EU
<b>AQUATAC™ FC-8560</b>	83	60	500	8.5	EU
<b>AQUATAC™ 2600</b>	98	59	670	7.5	US
<b>AQUATAC™ 2685</b>	84	58	750	8.6	US
<b>AQUATAC™ 6025</b>	30	62	5800	7.6	US
<b>AQUATAC™ 6085</b>	82	61	5300	7.4	US
<b>AQUATAC™ 9027</b>	27	89	160,000	9	US
<b>AQUATAC™ E 6180</b>	80	61	380	9.1	US

\* Please contact your Sales Manager for product availability in your region.

The values presented in this brochure are average values for typical resin samples and should not be construed as product specifications. Kraton test methods are available upon request.



## SYLVARES™ AMS Tackifiers

These aromatic tackifiers have a very light color, along with excellent oxidative stability. AMS resins can be used to modify styrene end blocks of SBC in order to improve the range of temperature performance. AMS resins may be used in EVA- and SBC-based adhesives for packaging, bookbinding, nonwovens and assembly applications.

Test	SP	Mw	Color	Tg	Manufacturing Region*
Method	AQCM 003	AQCM 217	AQCM 002	AQCM 218	
Unit	°C	g/mol	Hazen (1:1 toluene)	°C	
SYLVARES™ SA 85	84	1210	14	39	EU
SYLVARES™ SA 100	100	1540	20	52	EU
SYLVARES™ SA 115	116	2160	16	67	EU
SYLVARES™ SA 120	117	1880	22	70	EU
SYLVARES™ SA 140	137	4050	25	87	EU

\* Please contact your Sales Manager for product availability in your region.

## SYLVARES™ AMS Phenolic Tackifiers

The phenolic component of these tackifiers improves compatibility with high polarity polymers such as EVA, PUR and acrylics. AMS phenolic resins are recommended for use in applications that require water-white color, excellent adhesion and oxidative stability. The low Tg improves elasticity at low temperature, which makes these tackifiers suitable for bookbinding and packaging adhesives.

Test	SP	AN	Color	Tg	Manufacturing Region*
Method	AQCM 003	AQCM 217	AQCM 002	AQCM 218	
Unit	°C	g/mol	"Hazen (1:1 toluene)"	°C	
SYLVARES™ 520	75	940	26	38	EU
SYLVARES™ 540	76	880	24	38	EU
SYLVARES™ 525	94	1770	21	50	EU

\* Please contact your Sales Manager for product availability in your region.

The values presented in this brochure are average values for typical resin samples and should not be construed as product specifications. Kraton test methods are available upon request.

## SYLVARES™ Styrenated Terpene Tackifier

Adhesive formulators can benefit from the aliphatic-aromatic nature of styrenated terpenes, which result in high compatibility with EVA, SIS and SBS polymers. Kraton offers a non-limonene-based styrenated terpene, SYLVARES 6100. Combining broad compatibility and light color, it can be the right choice for premium hot-melt applications.

Test	SP	AN	Color	Tg	Manufacturing Region*
Method	AQCM 003	AQCM 217	AQCM 002	AQCM 218	
Unit	°C	g/mol	Gardner (neat)	°C	
<b>SYLVARES™ 6100</b>	97	1260	2	51	US

\* Please contact your Sales Manager for product availability in your region

## SYLVARES™ Polyterpene Tackifiers

Polyterpene grades with a high softening point have shown to combine high heat resistance and excellent tack and peel for pressure-sensitive adhesives. These resins offer the highest amount of biorenewable content of Kraton's product lines and are compatible with polyolefins and the mid-block of SIS co-polymers.

Test	SP	AN	Color	Tg	Manufacturing Region*
Method	AQCM 003	AQCM 217	AQCM 002	AQCM 218	
Unit	°C	g/mol	Gardner (neat)	°C	
<b>SYLVARES™ TR A25L</b>	26	420	5	-20	US
<b>SYLVARES™ TR B115</b>	115	1970	3	61	US
<b>SYLVARES™ TR M1115</b>	115	1750	2	60	US
<b>SYLVARES™ 3125</b>	126	1850	2	76	US

\* Please contact your Sales Manager for product availability in your region.

The values presented in this brochure are average values for typical resin samples and should not be construed as product specifications. Kraton test methods are available upon request.





# SYLVARES™ Terpene Phenolic Tackifiers

Our terpene phenolic resins are available in a wide range of polarities, which increases the versatility of adhesive formulation. High functionality terpene phenols provide outstanding adhesion when formulated with EVA and other polar polymers. The low polarity terpene phenolic resins improve adhesion of pressure-sensitive adhesives (in SIS, SBS and acrylic systems) to difficult-to-bond substrates like coated and recycled paper, glass and metal foils.

Test	SP	Mw	Color	Tg	Manufacturing Region*
Method	AQCM 003	AQCM 217	AQCM 002	AQCM 218	
Unit	°C	g/mol	Gardner (neat)	°C	
SYLVARES™ TP 300	112	790	4	68	US
SYLVARES™ TP 2040	119	710	4	71	US
SYLVARES™ TP 2019	124	900	4	74	US
SYLVARES™ TP 2040HM	126	850	4	78	US
SYLVARES™ TP 7042	148	980	4	97	US
SYLVARES™ TP 96	96	720	6	50	US
SYLVARES™ 1095	95	750	4	40	US
SYLVARES™ 1105	105	780	4	53	US
SYLVARES™ 1115	117	830	5	60	US
SYLVARES™ 1150	150	960	4	93	US
SYLVARES™ 1160	160	980	4	105	US

\* Please contact your Sales Manager for product availability in your region.

The values presented in this brochure are average values for typical resin samples and should not be construed as product specifications. Kraton test methods are available upon request.



# GLOBAL INTEGRATED TEAM APPROACH

We engage experts from a variety of disciplines to consult on challenges in order to solve them more effectively and efficiently for our customers.

## OUR WORLDWIDE MULTI-FUNCTIONAL TEAM PROVIDES:

Accessible and Personalized Technical Support Kraton technical service teams provide support from Innovation Centers located in China, the US and EU. We have inhouse capabilities to assist adhesive formulators with the selection of raw materials and to provide expert support from development to commercial application. The teams assist in scaleup trials and our Innovation Centers are equipped to fulfill adhesive application testing. Alongside our sales manager, the technical service teams regularly call on customers at all levels of the organization to provide training on our products.

## Hands-On Operational Assistance

To ensure that our communications with adhesive manufacturers are clear and complete, our operations personnel work closely with customers to enable smoother logistics across the supply chain. In order to improve process efficiency, we make site visits and interactive engineering exchanges that facilitate the review and understanding of particular technologies. We focus on continuous improvement in manufacturing and use root cause analysis to fully understand any issue that might arise.



PERSONALIZED  
SUPPORT FROM  
CHINA, EU AND  
US SCIENCE &  
TECHNOLOGY  
CENTERS

ENGINEERING  
SITE VISITS AND  
INTERACTIVE  
EXCHANGES



## EXPERT REGULATORY GUIDANCE

The highly-regulated chemical industry requires in-depth and current knowledge of the latest developments. Thanks to a dedicated global product regulatory team with comprehensive regional expertise, Kraton provides global support to customers on complex and changing regulations including EU Food Contact, US FDA Ingredient Status, international chemical control laws such as EU REACH, US TSCA, Japan CSCL and Decree 591 in China.

## INNOVATIVE SOLUTIONS

### TARGETED INNOVATION

Our innovation is driven by creativity, passion and active assessment of market trends. We work in state-of-the-art laboratories on technology platforms focused on pine rosin and terpene-based product opportunities. To ensure our innovation takes into account emerging customer needs, polymer advances and regulatory changes, we collaborate with adhesive manufacturers as well as internal and

external experts. Kraton's own analytical, rheology and regulatory teams support our global product development initiatives, and our continuous drive to understand structure property relationships. We encourage close cooperation, knowledge-sharing and transparency in our relationships with customers to take advantage of our combined strengths.

### ANALYTICAL EXPERTISE

Kraton has three highly-specialized analytical laboratories with advanced equipment and techniques that include (pyrolysis) GC-MS, (oxidative) DSC, TGA, GPC, HPLC, FTIR, NIR, UV-Vis, ICP - AES, sulfur analysis and preparative flash chromatography. Our chemists in the US, EU and China can perform in-depth analyses to characterize raw materials and adhesives, as well as investigate process and application issues.

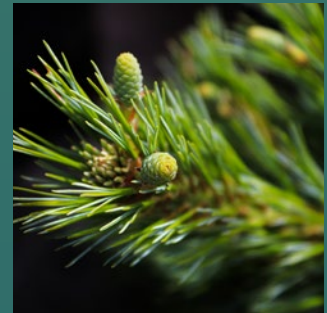

**INNOVATION  
DRIVEN BY  
CREATIVITY,  
PASSION AND  
CUSTOMER  
NEEDS**

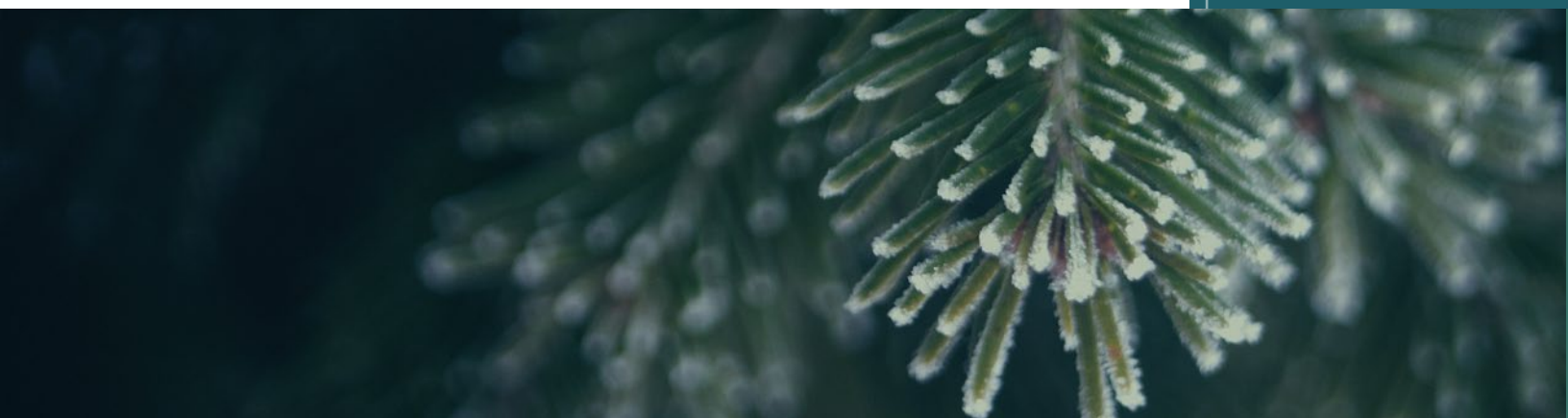

# Application Expertise

Our core competency in rheology, combined with sophisticated modeling techniques, form a solid base for enabling customers to achieve optimum product performance. Dynamic mechanical analysis (DMA), a rheology technique, is a powerful tool in generating a detailed understanding of how products and other individual ingredients interact without requiring the details of the total formulation. Viscoelastic profiles created using the DMA technique, in combination with the recently developed modeling approach, provide a strong base for problem-solving and formulation assistance that goes beyond tackifier selection.

CORE  
COMPETENCY IN  
RHEOLOGY AND  
USE OF  
SOPHISTICATED  
MODELING  
TECHNIQUES



## Typical viscoelastic response of a hot-melt pressure-sensitive adhesive system

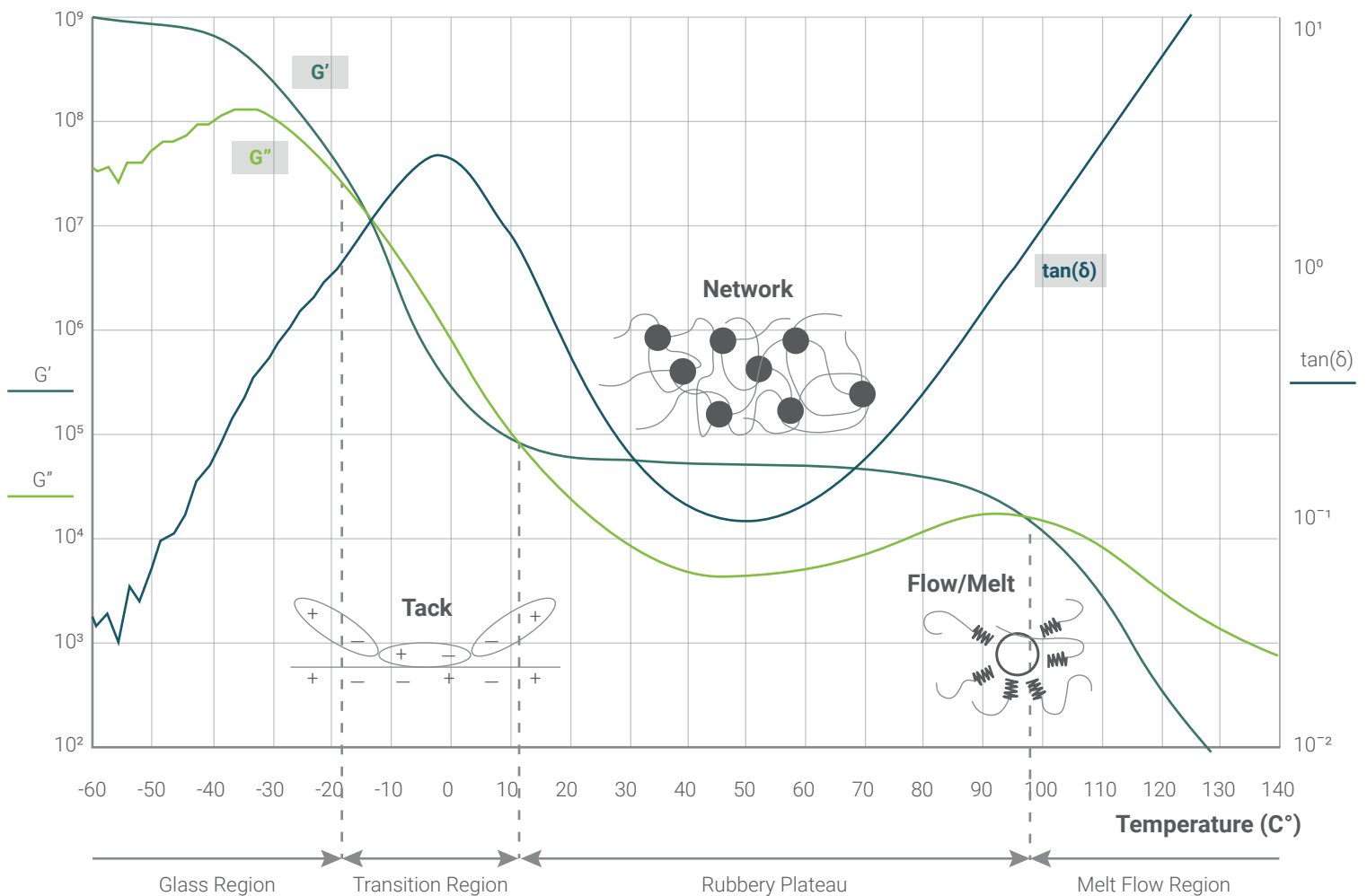

# GLOSSARY

<b>AES</b>	Atomic Emission Spectroscopy
<b>AMS</b>	Alpha Methyl Styrene
<b>AN</b>	Acid Number
<b>AQCM</b>	Arizona Quality Control Method
<b>ASTM</b>	American Society for Testing and Materials
<b>C-SBR</b>	Carboxylated Styrene Butadiene Rubber
<b>CSCL</b>	Chemical Substance Control Law
<b>DMA</b>	Dynamic Mechanical Analysis
<b>DoE</b>	Design of Experiment
<b>DSC</b>	Differential Scanning Calorimetry
<b>EVA</b>	Ethyl Vinyl Acetate
<b>FDA</b>	Food and Drug Administration
<b>FTIR</b>	Fourier transform infrared spectroscopy
<b>GC-MS</b>	Gas Chromatography Mass Spectrometry
<b>GPC</b>	Gel Permeation Chromatography
<b>HPLC</b>	High Performance Liquid Chromatography
<b>ICP</b>	Inductively Coupled Plasma
<b>Mw</b>	Molecular Weight
<b>NIR</b>	Near-Infrared
<b>OH</b>	Hydroxyl Value
<b>PSA</b>	Pressure Sensitive Adhesives
<b>PUR</b>	Polyurethane
<b>REACH</b>	Registration, Evaluation, Authorisation and Restriction of Chemicals
<b>SBC</b>	Styrenic Block Co-polymers
<b>SBR</b>	Styrene Butadiene Rubber
<b>SBS</b>	Styrene Butadiene Styrene
<b>SIS</b>	Styrene Isoprene Styrene
<b>SP</b>	Softening Point
<b>Tg</b>	Glass Transition Temperature
<b>TGA</b>	Thermogravimetric Analysis
<b>UV-Vis</b>	Ultraviolet-Visible
<b>VA</b>	Vinyl Acetate

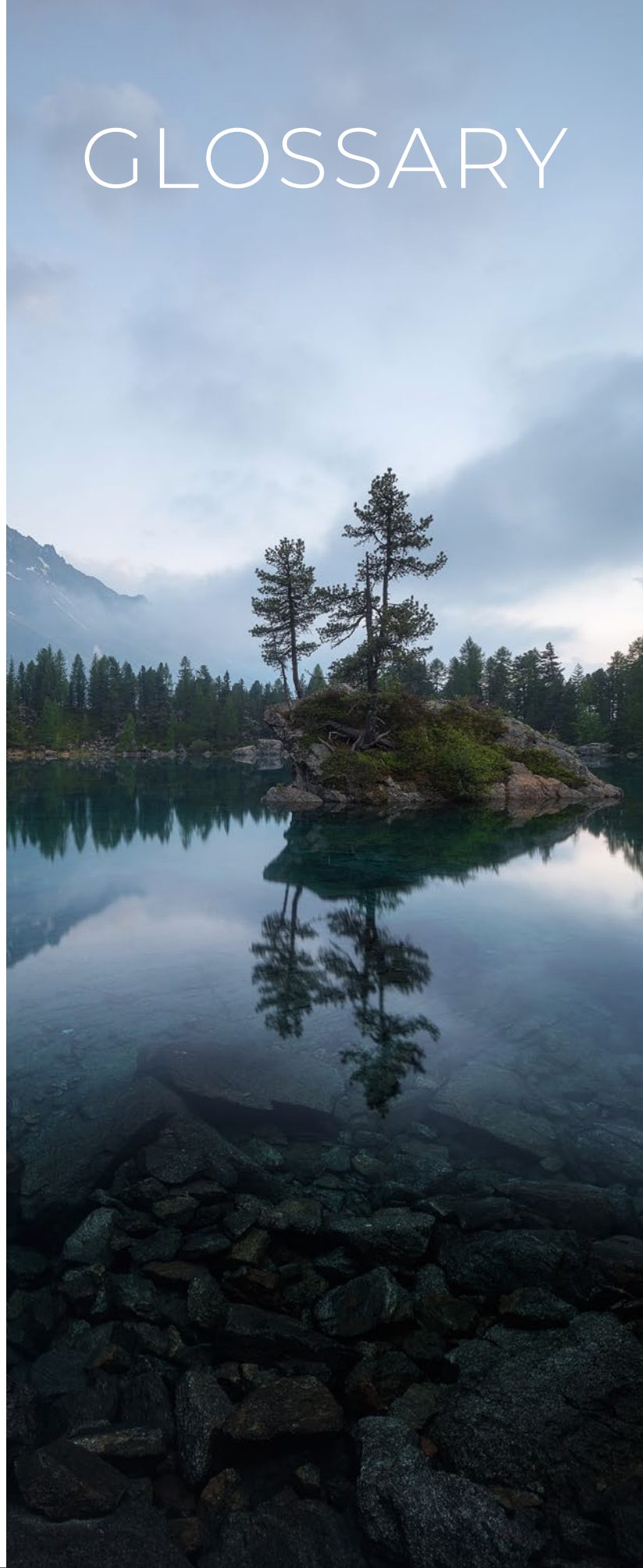

# KRATON

## GLOBAL FOOTPRINT

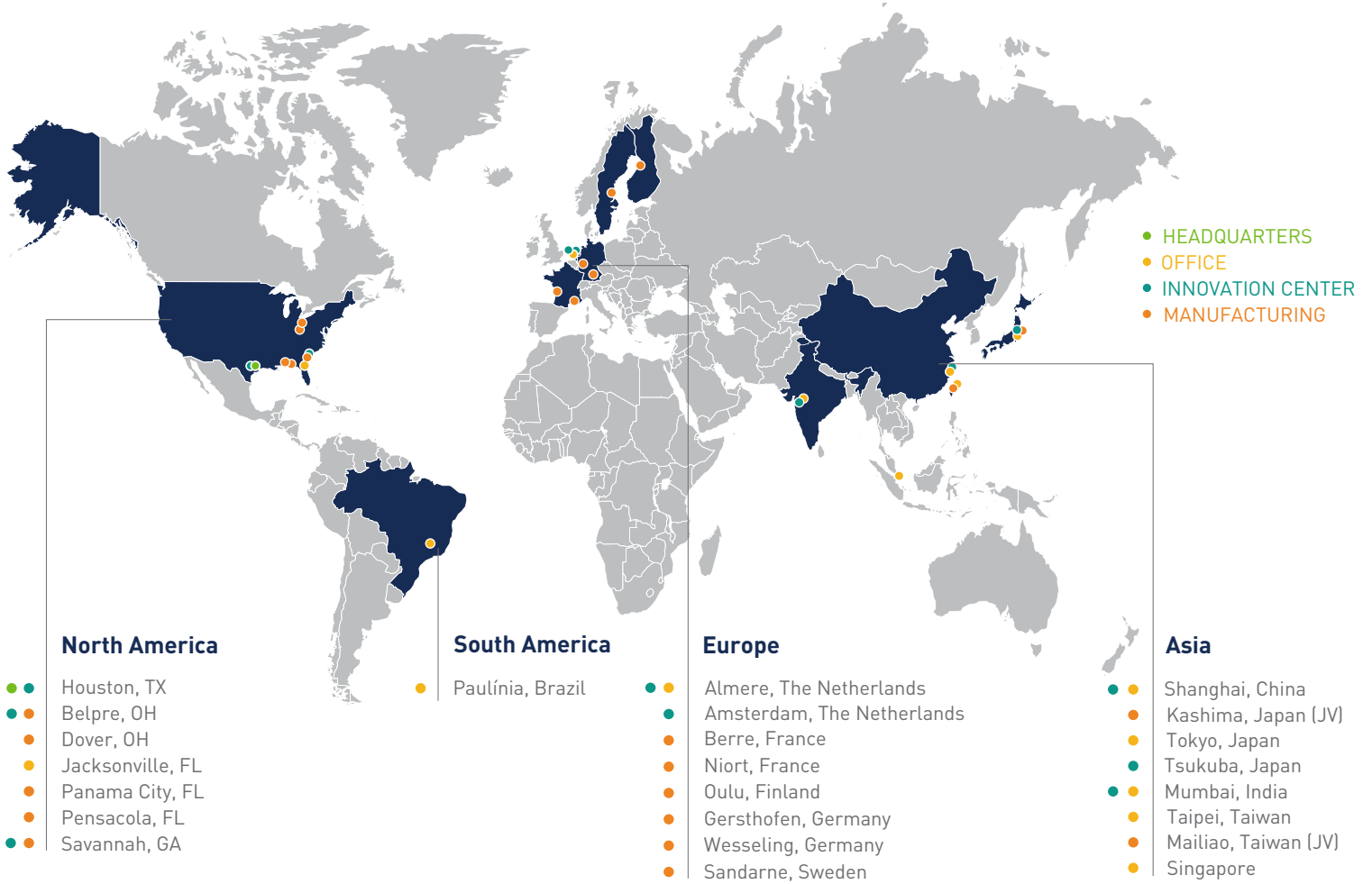

### KRATON CORPORATION

For more information, visit our website at [www.kraton.com](http://www.kraton.com).

U.S.A. Headquarters  
Houston, Texas

Asia Pacific  
Shanghai, China

Europe, Africa, Middle East  
Almere, The Netherlands

India/ Southeast Asia  
Mumbai, India



The information herein is for general information purposes only. While it is believed to be reliable, no representations, guarantees or warranties of any kind are made as to its completeness, accuracy, reliability, or suitability for applications or the results to be obtained therefrom.

\*Kraton, SYLVATAC, and the tagline "Sustainable Solutions. Endless Innovation." are trademarks of Kraton Corporation or its affiliates.